

The large capacity 2-Tier Zone 8 is ideal for merchandising pre-packaged hot foods and increasing impulse sales in the Deli or anywhere else in your store.

The mirrored doors on the back enhance the products on display by making the case look fuller. They also allow the operator to see into the case while preventing customers from looking through into the deli area.



RELIABLE



EASY CLEAN



PATENTED DESIGN



## Increase Impulse Sales

This versatile hot case can be placed in high-traffic areas and will attract attention with its illuminated signage and abundant lighting.

## Consistently Keeps Products in the Safe Zone

An innovative patented heating technology delivers even heat from corner to corner, keeping products above 140°F without overheating. Thermostats in independently controlled temperature zones are strategically located to ensure even heat distribution.

## No Training Required

The ON/OFF switch controls temperature and lighting. Surface-mounted temperature strips indicate when the unit is warm enough to safely accept food, eliminating operator guesswork. Convenient sliding glass doors on the rear (mirrored on the customer side) allow for easy access.

## Easy Cleaning

Removable parts as well as all stainless steel holding surfaces makes for easy cleaning.

## Extremely Reliable

In an ongoing study of over 2 million operating days, Zone Hot Cases have achieved 99.997% reliability. Virtually no maintenance costs.

## Safety

Lexan heat shields protect users from coming in contact with hot surfaces while reaching for products.

## Large Capacity

Easily accommodates up to 56 chicken domes.

## Advantages

Hold it Safely



Keep it Fresh



Patented Technology



No Training Required



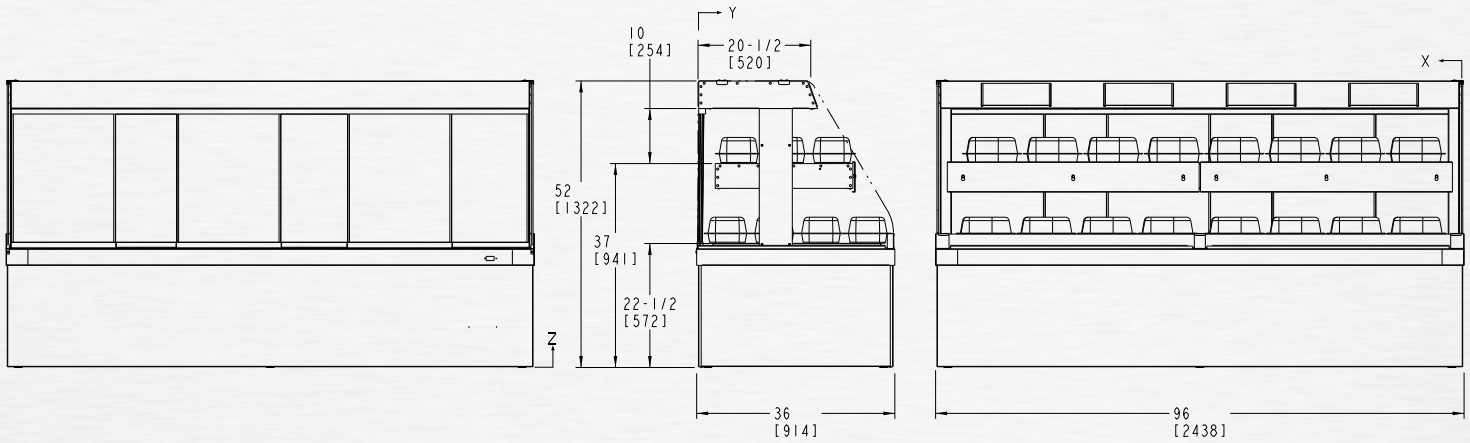

ref 99-9575-2

## Electrical Configuration

Supply Voltage	Configuration	Peak Power Consumption
208/120 VAC	All 100 Watt Lamps	4606 Watts
240/120 VAC	All 100 Watt Lamps	5372 Watts

## Warranty

2 Years Parts & Labor

## Other Available Sizes

## Notes

- Capacity: 56 chicken domes or equivalent
- Shipping weight: Approx. 780 lbs
- Electrical supply may be either 208/120VAC or 240/120VAC having a single phase, 50/60 Hz, 4-wire supply (2-hot, 1-neutral, 1-ground) equipped with a 2-pole circuit breaker.

## Options

- Bumper, base and backlit signage customizable
  - 10-foot power cable with a 50A plug
  - 120VAC 15A GFCI accessory receptacle in base\*
- \* Requires a designated permanent electrical supply.  
Not available in conjunction with the power cable function.

## Many Styles & Sizes of Hot Cases Available



2-Tier Zone 6

42 Chicken Domes

W72" x D36"

3 Tier In-Line



Island



Combo



For the complete list of Zone products, please visit our web site: [hardtequipment.com](http://hardtequipment.com)